

ML Series Maximum Power Point Tracking Solar Charge and Discharge Controller

SR-ML2420

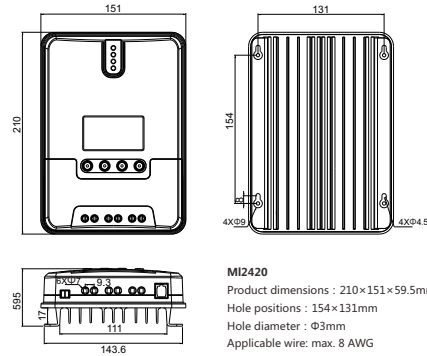

SR-ML2420

Features

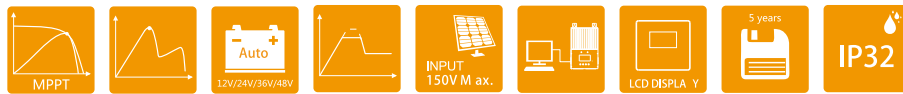

1. With the advanced dual-peak or multi-peak tracking technology, when the solar panel is shadowed or part of the panel fails resulting in multiple peaks on the I-V curve, the controller is still able to accurately track the maximum power point.
2. A built-in maximum power point tracking algorithm can significantly improve the energy utilization efficiency of photovoltaic systems, and raise the charging efficiency by 15% to 20% compared with the conventional PWM method.
3. A combination of multiple tracking algorithms enables accurate tracking of the optimum working point on the I-V curve in an extremely short time.
4. The product boasts an optimum MPPT tracking efficiency of up to 99.9%.
5. Advanced digital power supply technologies raise the circuit's energy conversion efficiency to as high as 98%.
6. Charging program options are available for different types of batteries including gel batteries, sealed batteries, open batteries, lithium batteries, etc.
7. The controller features a limited current charging mode. When the solar panel power exceeds a certain level and the charging current is larger than the rated current, the controller will automatically lower the charging power and bring the charging current to the rated level.
8. Instantaneous large current startup of capacitive loads is supported.
9. Automatic recognition of battery voltage is supported.
10. LED fault indicators and an LCD screen which can display abnormality information help users to quickly identify system faults.
11. Historical data storage function is available, and data can be stored for up to a year.
12. The controller is equipped with an LCD screen with which users can not only check device operating data and statuses, but also modify controller parameters.
13. The controller supports standard Modbus protocol, fulfilling the communication needs of various occasions.
14. The controller employs a built-in over-temperature protection mechanism. When temperature surpasses the set value, the charging current will decline in linear proportion to the temperature so as to curb the temperature rise of the controller, effectively keeping the controller from being damaged by overheating.
15. Featuring a temperature compensation function, the controller can automatically adjust charging and discharging parameters in order to extend the battery's service life.
16. TVS lighting protection.

Parameter

Parameter	Value
Model	ML2420
System voltage	12V/24VAuto
No-load loss	0.7 W to 1.2W
Battery voltage	9V to 35V
Max. solar input voltage	100V(25°C) 90V(-25°C)
Max. power point voltage range	Battery Voltage+2V to 75V
Rated charging current	20A
Rated load current	20A
Max. capacitive load capacity	10000uF
Max. photovoltaic system input power	260W/12V 520W/24V
Conversion efficiency	≤98%
MPPT tracking efficiency	>99%
Temperature compensation factor	-3mv/°C/2V (default)
Operating temperature	-35°C to +45°C
Protection degree	IP32
Weight	1.4Kg
Communication method	RS232
Altitude	≤ 3000m
Product dimensions	210×151×59.5mm

Comparison Table of Parameters for Each Type of BatterySetting Voltage

Battery Type	Sealed Lead-Acid Battery	Gelled Lead-Acid Battery	Open Lead-Acid Battery	User (User-Defined)Overvoltage
Disconnect Voltage	16.0V	16.0V	16.0V	9 ~ 17V
Equalizing Voltage	14.6V	---	14.8V	9 ~ 17V
Boost Voltage	14.4V	14.2V	14.6V	9 ~ 17V
Floating Voltage	13.8V	13.8V	13.8V	9 ~ 17V
Boost Restoring Voltage	13.2V	13.2V	13.2V	9 ~ 17V
Low Voltage Disconnect Restoring Voltage	12.6V	12.6V	12.6V	9 ~ 17V
Under-Voltage Alarming Restoring Voltage	12.2V	12.2V	12.2V	9 ~ 17V
Under-Voltage Alarming Voltage	12.0V	12.0V	12.0V	9 ~ 17V
Low Voltage Disconnect Voltage	11.1V	11.1V	11.1V	9 ~ 17V
Discharging Limit Voltage	10.6V	10.6V	10.6V	9 ~ 17V
Over-Discharge Delay Time	5s	5s	5s	1 ~ 30s
Equalizing Duration Time	120Min	---	120Min	0 ~ 600Min
Equalizing Charging Interval	30Days	0Day	30Days	0 ~ 250D (0 refers to close equalizing charging function)
	120Min	120Min	120Min	10 ~ 600Min

The User battery is customized battery. The system's default voltage parameters are consistent with sealed lead-acid battery parameters. When modifying battery charging and discharging parameters, observe the following logic:

- ◆ Overvoltage Disconnect Voltage > Charging Limit Voltage ≥ Equalizing Voltage ≥ Boost Voltage ≥ Floating Charging Voltage > Boost Restoring Voltage ;
- ◆ Overvoltage Disconnect Voltage > Overvoltage Disconnect Restoring Voltage ;
- ◆ Low Voltage Disconnect Restoring Voltage > Low Voltage Disconnect Voltage ≥ Discharging Limit Voltage ;
- ◆ Under-Voltage Alarming Restoring Voltage > Under-Voltage Alarming Voltage ≥ Discharging Limit Voltage ;
- ◆ Boost Restoring Voltage > Low Voltage Disconnect Restoring Voltage ;

